

Backers	
Description	Length
2x6 Backer	2' - 4 7/32"
2x6 Backer	2' - 4 7/32"
	4' - 8 13/32"

Plumbing Utilities		
Mark	Description	Qty
H	Hot Water Supply	1
C	Cold Water Supply	1
D	Sanitary DWV	1

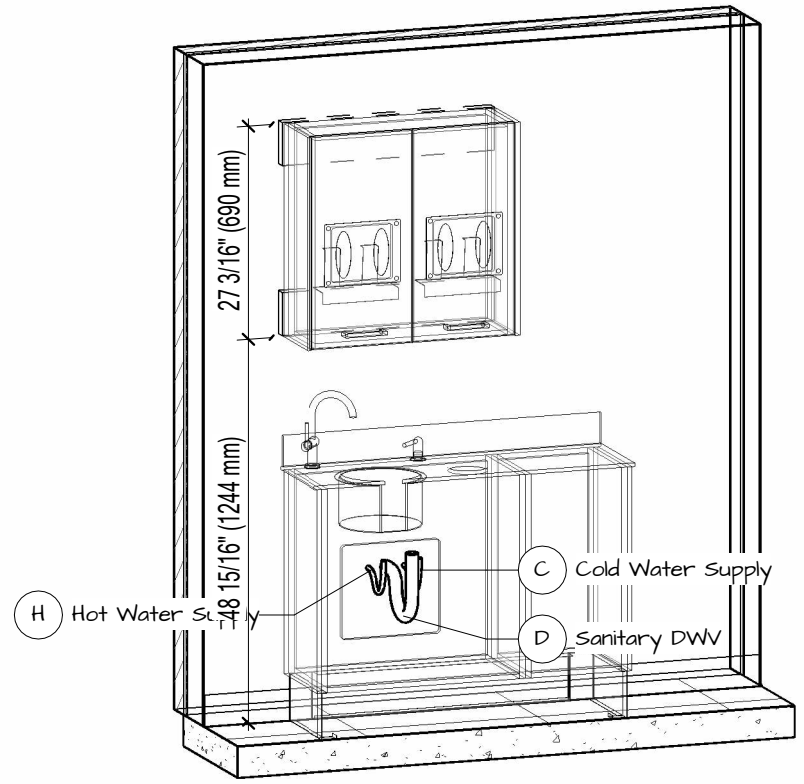

1 Utilities Location

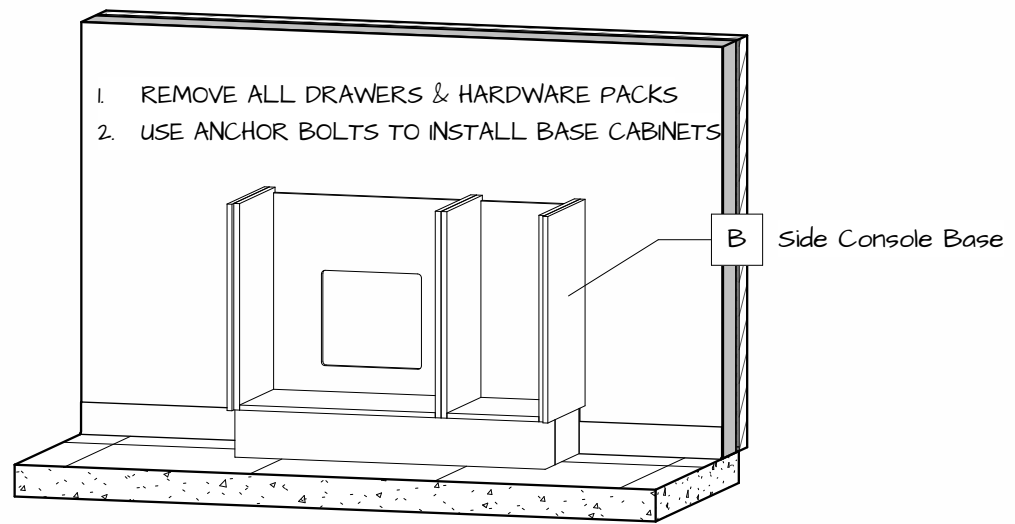

2.1 Install Base Cabinets

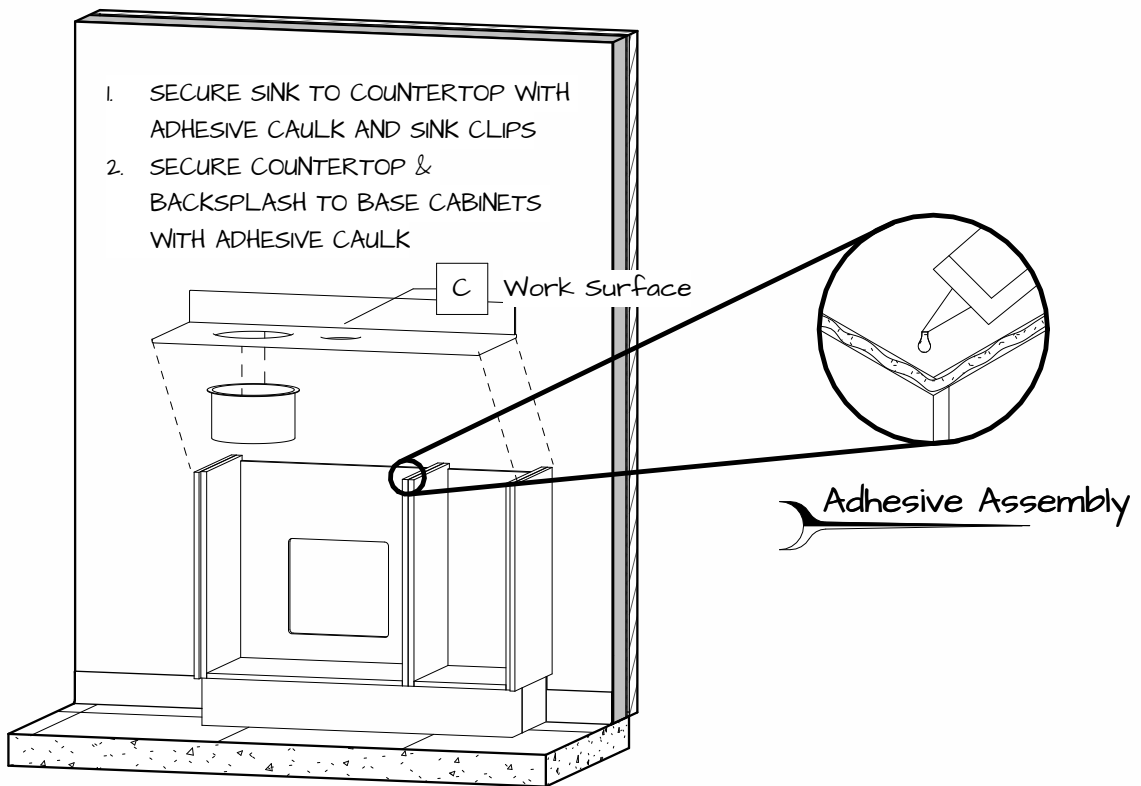

2.2 Install CounterTop

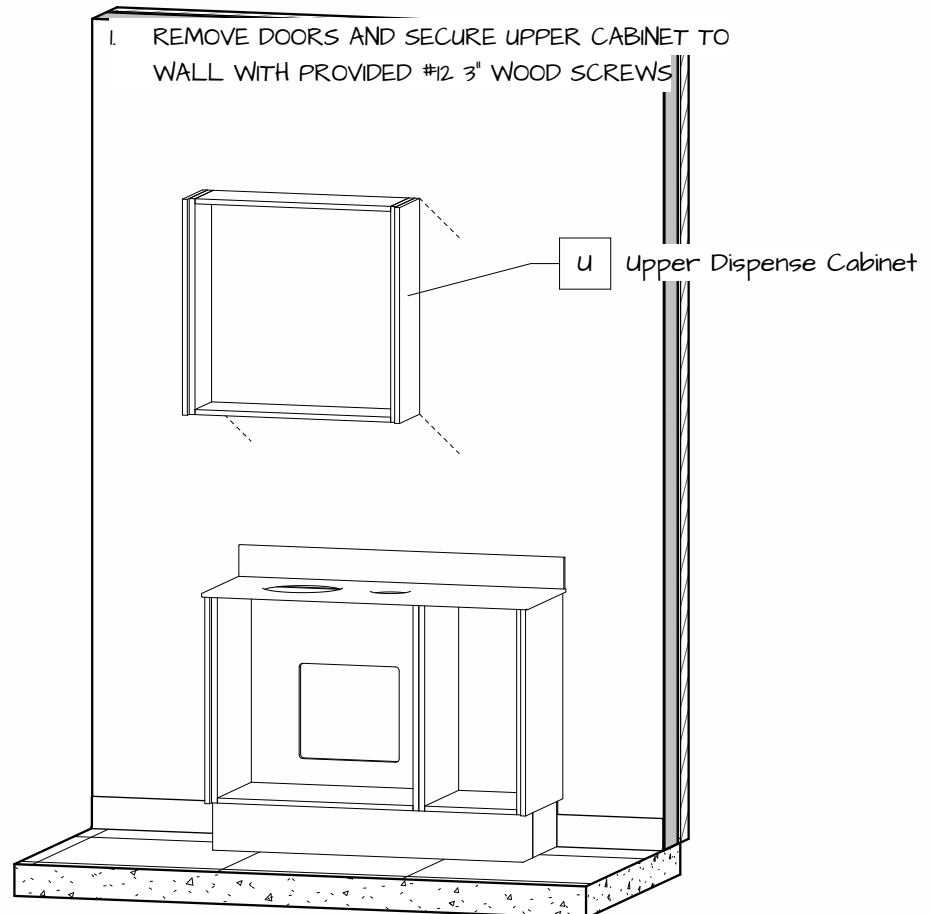

2.3 Install Upper Cabinets

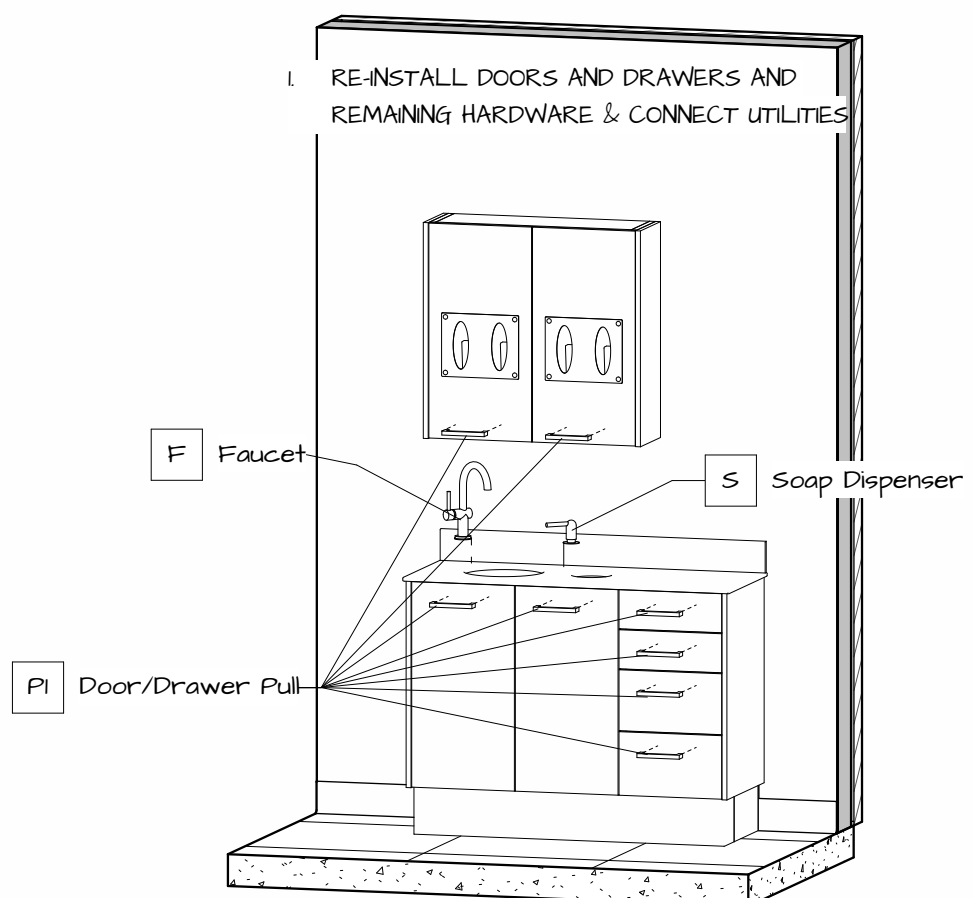

2.4 Install Hardware

Packing List		
Mark	Description	Qty
	#12 3" Wood Screws	4
	Anchor Bolts	4
	Sink	1
	Strainer	1
	Tube of Caulk	1
B	Side Console Base	1
C	Work Surface	1
F	Faucet	1
Pl	Door/Drawer Pull	8
S	Soap Dispenser	1
U	Upper Dispense Cabinet	1

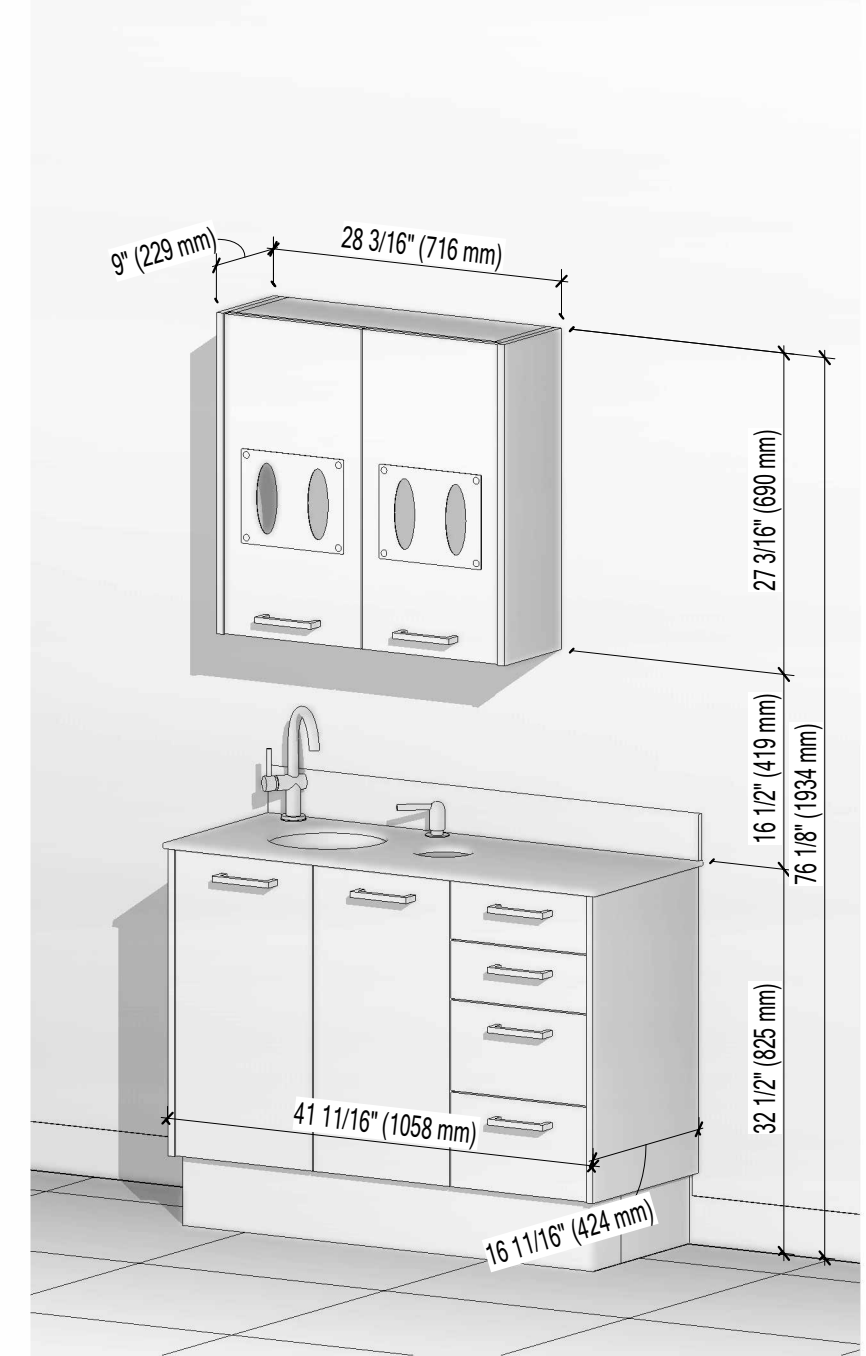

3 Final Installation View

anthos
NOVA Solutions Inc.
217-342-7070
sales@novasolutionsinc.com

Installation Drawing		Prepared For: NOVA Solutions Inc.
LINEA		
Project	SIDE TREATMENT CENTER	I-1
Item #	ALSTC 03A-000-U31	
Drawn by:	Justin Martin	09/05/24
		Rev. 1