

1 Utilities Location

Backers	
Description	Length
2x6 Backer	4' - 7 1/8"
2x6 Backer	4' - 7 1/8"
	9' - 2 9/32"

Packing List		
Mark	Description	Qty
	#12 3" Wood Screws	6
	Anchor Bolts	8
	Tube of Caulk	1
B	Side Console Base	1
C	Work Surface w/ Sink	1
P1	Door/Drawer Pull	14
U	Upper Storage Cabinet	1

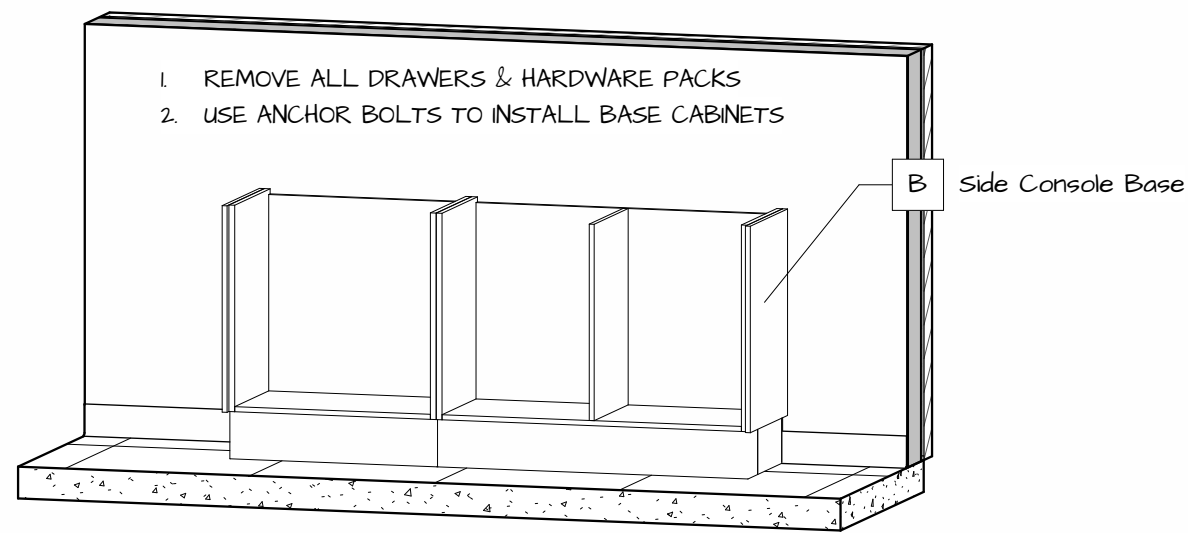

2.1 Install Base Cabinets

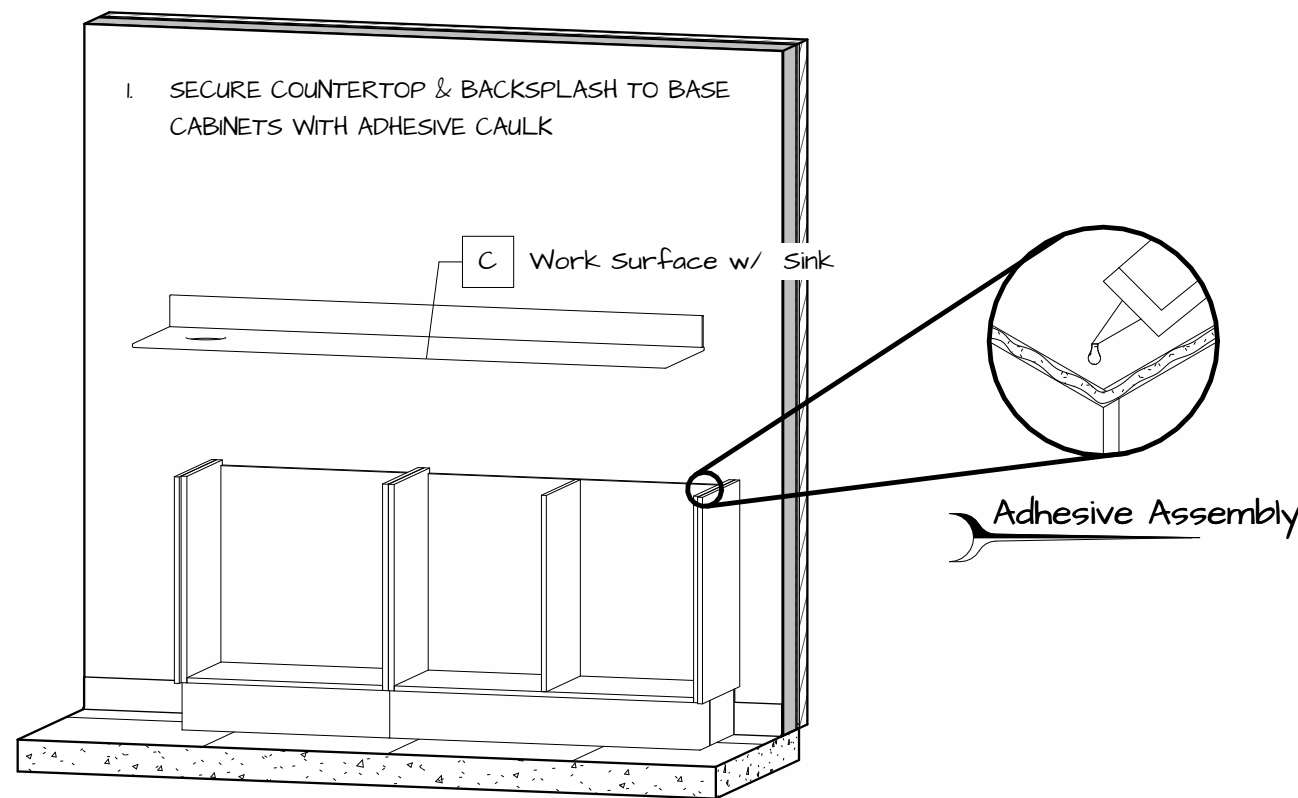

2.2 Install CounterTop

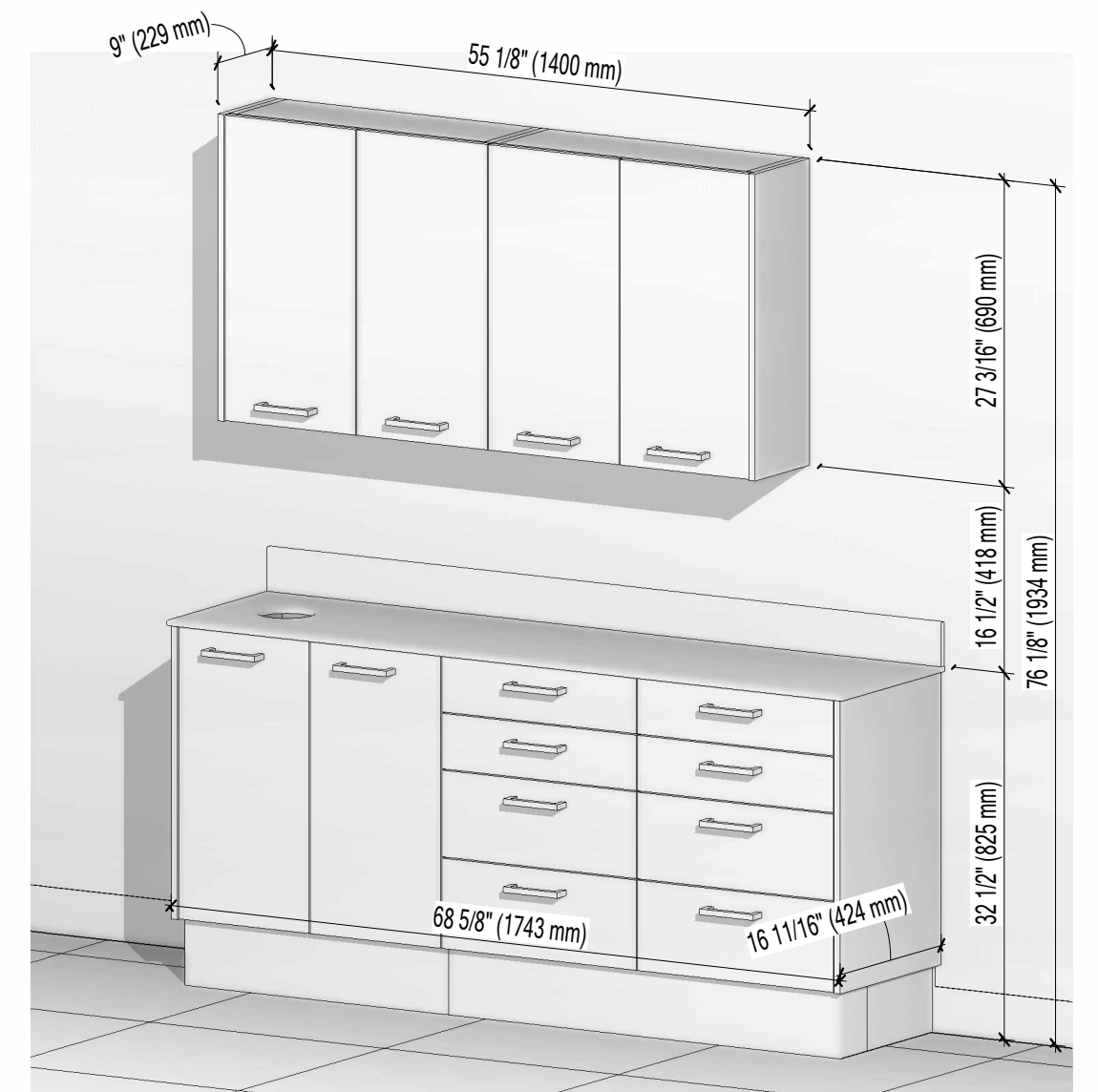

3 Final Installation View

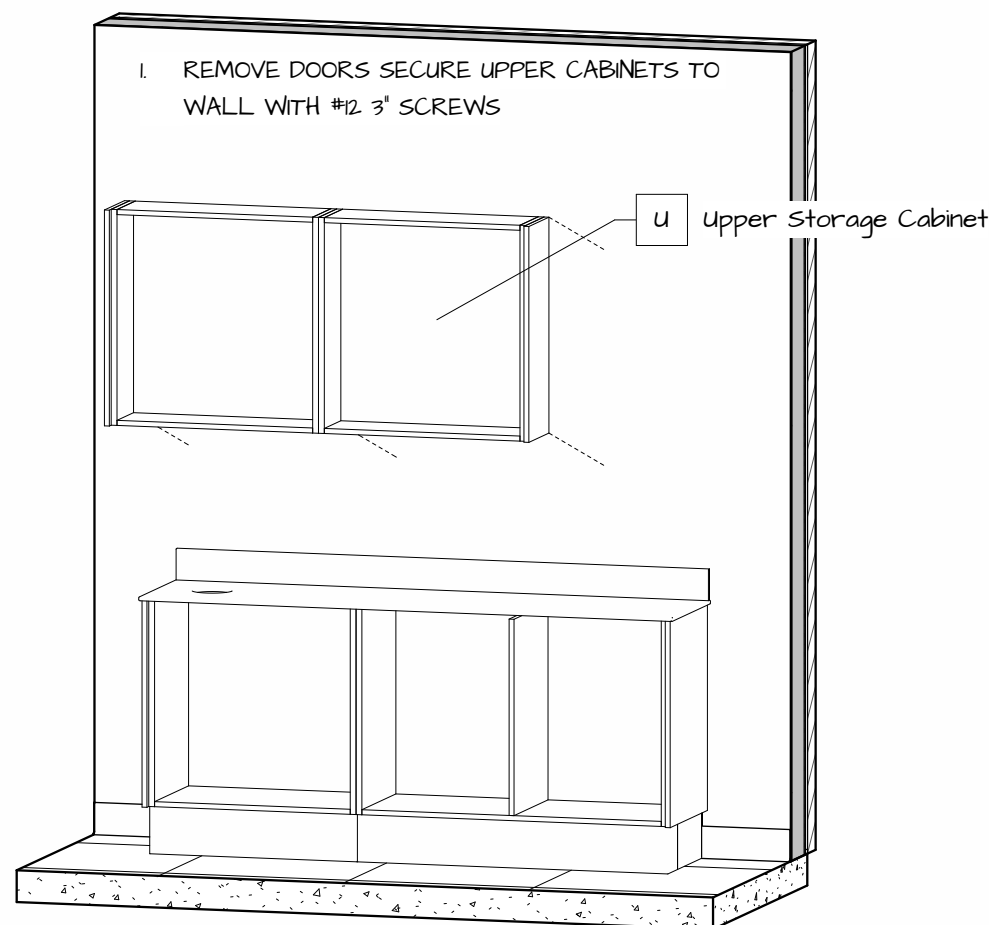

2.3 Install Upper Cabinets

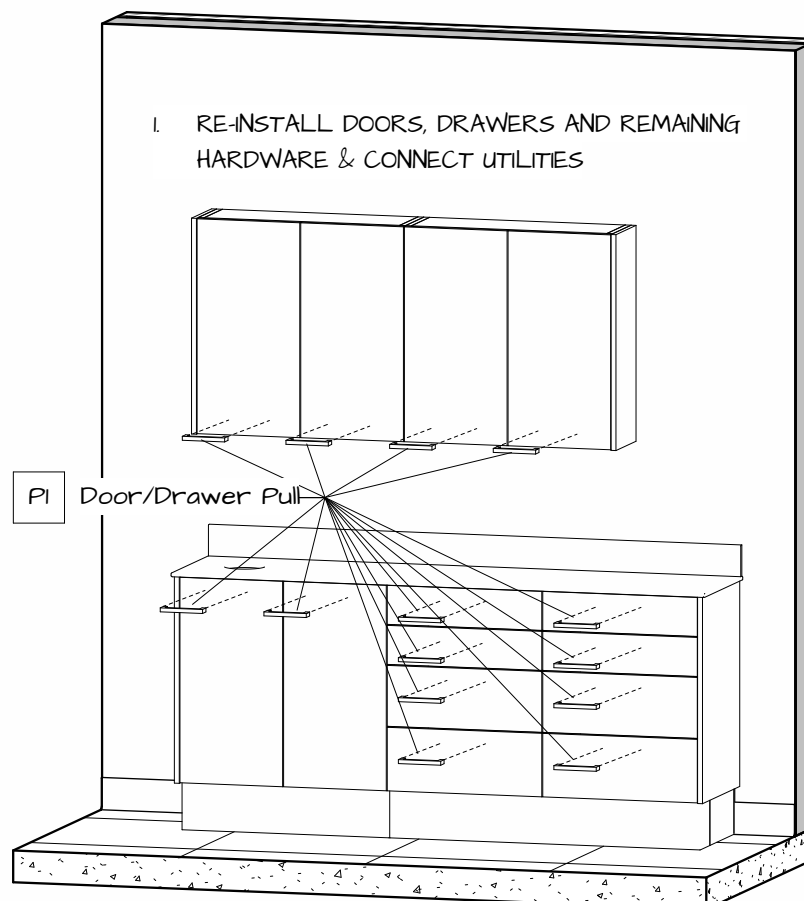

2.4 Install Hardware

anthos
NOVA Solutions Inc.
217-342-7070
sales@novasolutionsinc.com

Installation Drawing		Prepared For: Nova Solutions Inc.
LINEA		
Project	REAR TREATMENT CENTER	I-1
Item #	ALSTC 03M-000-U35	
Drawn by:	Justin Martin	09/27/24
		Rev. 1